



### Description

Gas Discharge Tube (GDT) is a single-gap or multi-gap switching overvoltage protection device. Under normal circumstances, the GDT is in a high-impedance state; when suffer a surge, the GDT will change from a high-impedance state to a low-impedance state, and release the surge energy to the ground, reducing the residual voltage of the circuit, thereby protecting the equipment circuit or protect the human body from the hazards of transient overvoltage. GDT is formed by high-temperature sealing of metal electrodes, metallized ceramics, inert gas or other mixed gases.

### Features

- Fast Response
- Stable Performance Over Surface Life
- High Current Rating
- Low Capacitance
- High Insulation Resistance
- RoHS & REACH Compliant

### Agency Information

| Agency Symbol | Standards | The File No. and certification No. obtained by SETsafe   SETfuse |
|---------------|-----------|--|
|               | UL1449    | E322662  |
|               | UL1449    | E322662  |

### Applications

- Surge Protective Device
- New Energy

### Part Numbering System

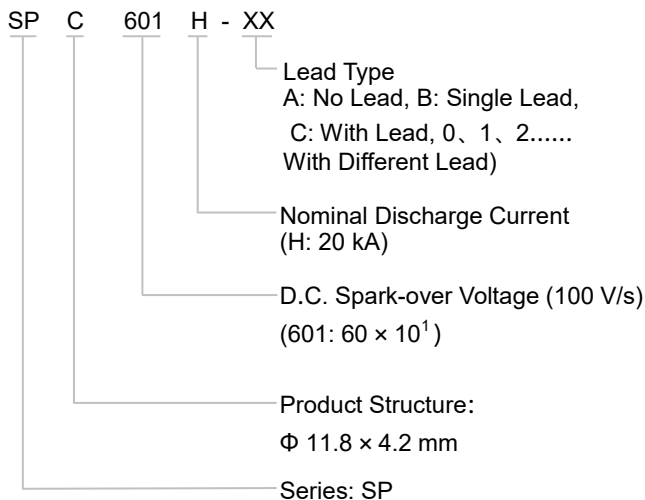

### Dimensions (mm)

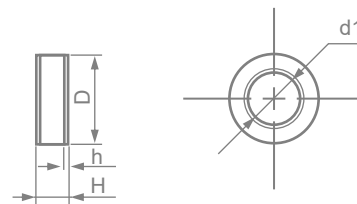



| D                   | d <sub>1</sub> | H             | h   |
|---------------------|----------------|---------------|-----|
| $\Phi 11.8 \pm 0.3$ | $\Phi 6.8$     | $4.2 \pm 0.5$ | 0.8 |

Notes: May increase each kind of connect mode according to the customer different demand.

#### Reminder:

Part numbering system in the datasheet is only for selecting correct parameter and product features. Before placing order, please contact us for specifications and use the part number and product code in the specifications to place order to ensure the part is correct. Product code is the unique identification.

**Specifications**

|  |            |   |              |   |              |   |              |  |       |
|--|------------|---|--------------|---|--------------|---|--------------|--|-------|
| Model  | SPC351H-XX |   | SPC601H - XX |   | SPC801H - XX |   | SPC102H - XX |  | Units |
| Category   | II         |   | II           |   | II           |   | II           |  |       |
| Application  | N - PE     |   | N - PE       |   | N - PE       |   | N - PE       |  |       |
| Nominal D.C. Spark-over Voltage (100 V/s)            | 350        |   | 600          |   | 800          |   | 1000         |  | V     |
| D.C. Spark-over Voltage (100 V/s)                    | 280 ~ 420  |   | 480 ~ 720    |   | 640 ~ 960    |   | 800 ~ 1200   |  | V     |
| Impulse Spark-over Voltage @1 kV/μs                  | < 900      |   | < 1400       |   | < 1600       |   | < 1800       |  | V     |
| <b>GB/T18802.311</b>                                 |            |   |              |   |              |   |              |  |       |
| Nominal Impulse Discharge Current @8/20 μs $I_n$     | 20         |   | 20           |   | 20           |   | 20           |  | kA    |
| Maximum Impulse Discharge Current @8/20 μs $I_{max}$ | 40         |   | 40           |   | 40           |   | 40           |  | kA    |
| <b>Class I / II (Comply with IEC61643-11)</b>        |            |   |              |   |              |   |              |  |       |
| Max Continuous Operating Voltage $U_c$ 50/60 Hz      | 110        |   | 255          |   | 255          |   | 320          |  | Vrms  |
| Follow Current Cut-off Ability AC 50/60 Hz $I_f$     | 100        |   | 100          |   | 100          |   | 100          |  | Arms  |
| Nominal Discharge Current @8/20 μs $I_n$             | 20         |   | 20           |   | 20           |   | 20           |  | kA    |
| Maximum Discharge Current @8/20 μs $I_{max}$         | 40         |   | 40           |   | 40           |   | 40           |  | kA    |
| Insulation Resistance (100 VDC)                      | > 1000     |   | > 1000       |   | > 1000       |   | > 1000       |  | MΩ    |
| Capacitance at 100 kHz                               | < 5        |   | < 5          |   | < 5          |   | < 5          |  | pF    |
| Agency Approvals                                     | UL1449     |  | ○            | ● | ○            | ● |              |  |       |
|  | UL1449     |  | ○            | ● | ○            | ● |              |  |       |
|  | TUV        |  | ○            | ○ | ○            | ○ |              |  |       |

Note:

1. The above parameters based on ITU-T K12 & IEC61643.311、IEC61643.11 standards.
2. Connect mode according to the customer different demand.
3. “●” means GDT has gained the certification, “○” means GDT is no certification.
4. Operating Temperature -40 °C ~ +125 °C .

**Electrical Characteristics**

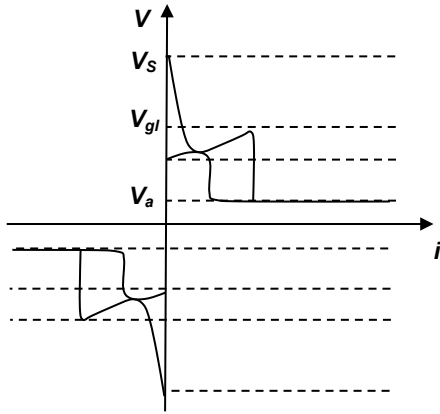

Relationship between Current and Voltage

- $V_s$  : Spark-over Voltage
- $V_{gl}$  : Glow Voltage
- $V_a$  : Arc Voltage
- G : Glow Mode
- A : Arc Mode

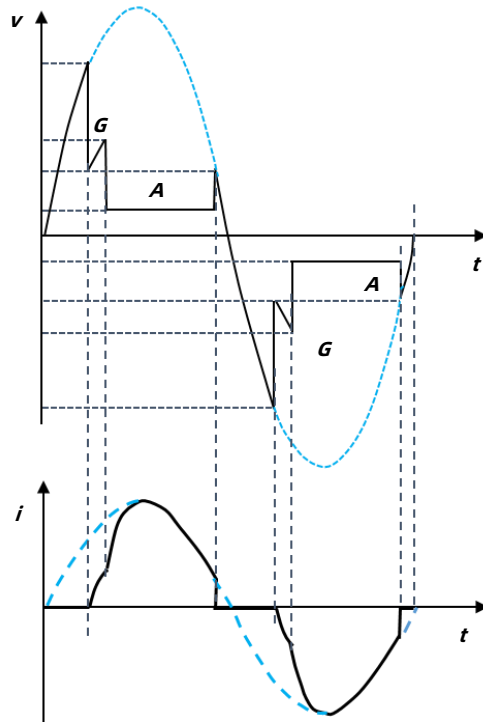

Time Variation Patterns of Voltage and Current

**Reference Curve for Spark-over Voltage (Refer to 230 VDC)**



**Curve for Impulse Discharge Current (For Reference Only)**

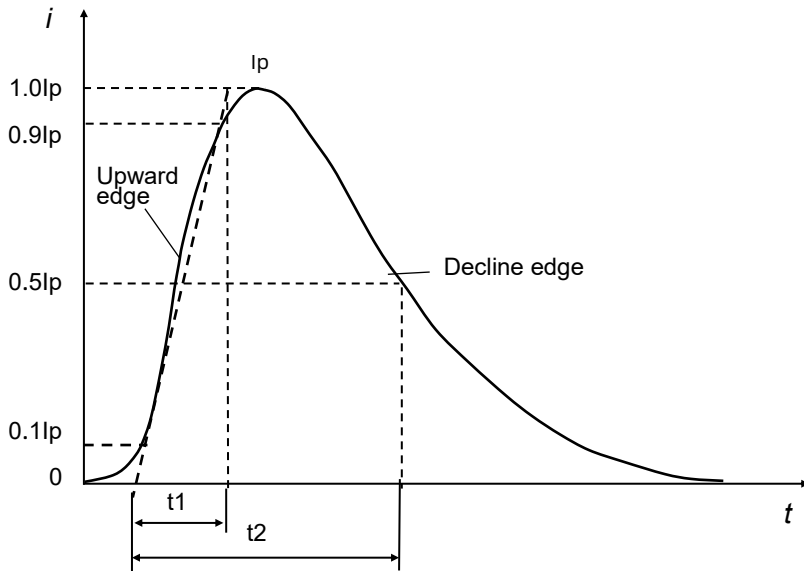

$I_p$ : Peak current  
 $t_1$ : Rise time in  $\mu s$   
 $t_2$ : Delay time to half value in  $\mu s$

**Application Example (For Reference Only)**

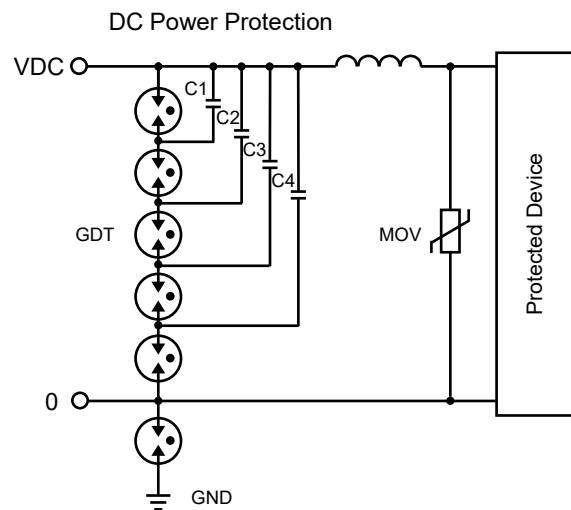
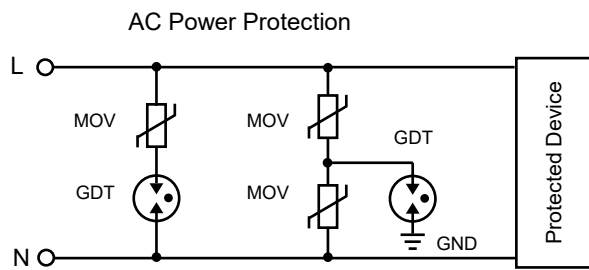

### Recommended Hand-soldering Parameters (For Reference Only)

| Items  | Condition                        |
|--|----------------------------------|
| Soldering Iron Temperature                     | 350 °C (Max.)                    |
| Soldering Time                                 | 4 s (Max.)                       |
| Space between soldering point and product body | According to the guidance method |

### Wave Soldering Parameters (For Reference Only)

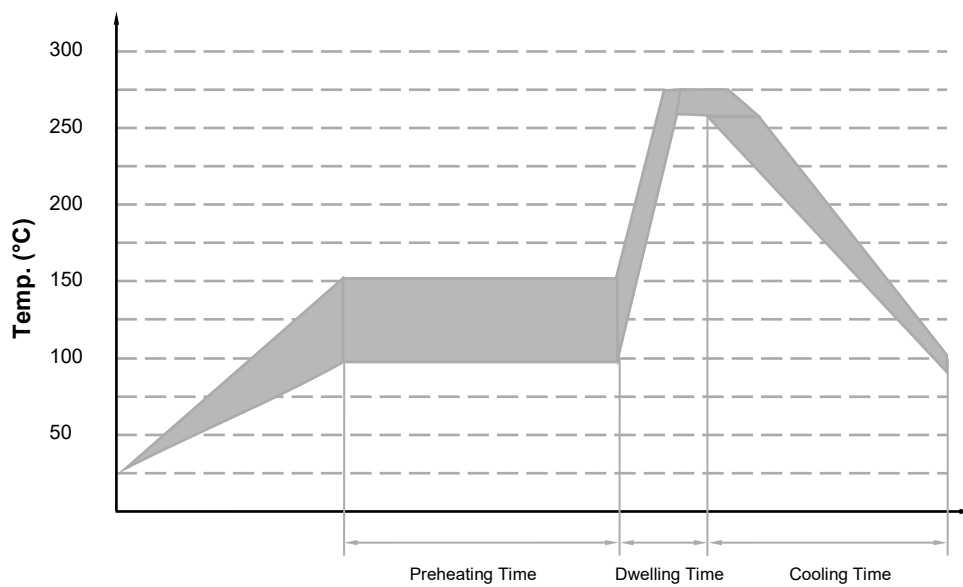

| Item       | Temp. (°C) | Time (s) |
|------------|------------|----------|
| Preheating | 90 to 150  | < 150    |
| Dwelling   | 255 to 280 | 3 to 10  |

**Reflow Soldering Parameters (For Reference Only)**

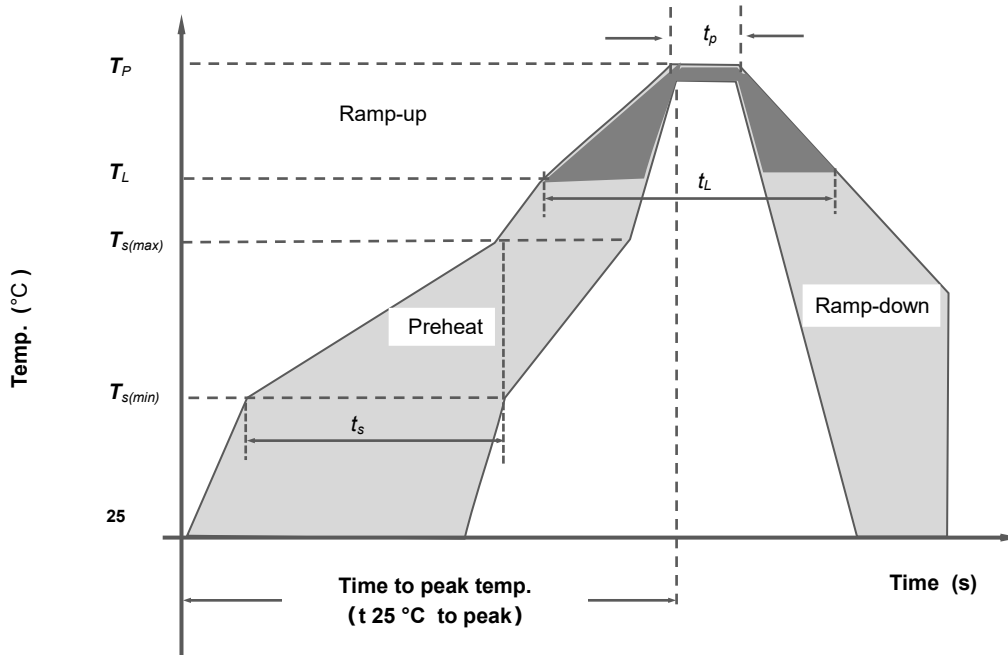

| Reflow Condition  |                            | Pb-Free Assembly  |
|---|----------------------------|-------------------|
| Preheat   | Temp. Min $T_{s(min)}$     | 150 °C            |
|   | Temp. Max $T_{s(max)}$     | 200 °C            |
|   | Time (Min to Max) $t_s$    | (60 to 180) s     |
| Average ramp up rate (Liquidus Temp. ( $T_L$ ) to peak) |                            | 3 °C / second max |
| $T_{s(max)}$ to $T_L$ Ramp-up Rate                      |                            | 5 °C / second max |
| Reflow  | Temp. ( $T_L$ ) (Liquidus) | 217 °C            |
|   | Temp. ( $t_L$ )            | (60 to 150) s     |
| Peak Temp. ( $T_P$ )                                    |                            | (255 to 260) °C   |
| Time within 5 °C of actual peak Temp. ( $t_p$ )         |                            | (10 to 30) s      |
| Ramp-down Rate  |                            | 6 °C / second max |
| Time 25 °C to peak Temp. ( $T_P$ )                      |                            | 8 minutes max     |
| Do not exceed   |                            | 260 °C            |

## Packaging Information

### PE Box Package

| Item   | PE Box         | Inner Box      | Carton          |
|--|----------------|----------------|-----------------|
| Dimensions (mm)  | 225 × 205 × 16 | 230 × 210 × 98 | 440 × 250 × 250 |
| Quantity (PCS)   | 192            | 960            | 3840            |
| Notes: Packaging dimensions and quantity are for reference only. |                |                |                 |

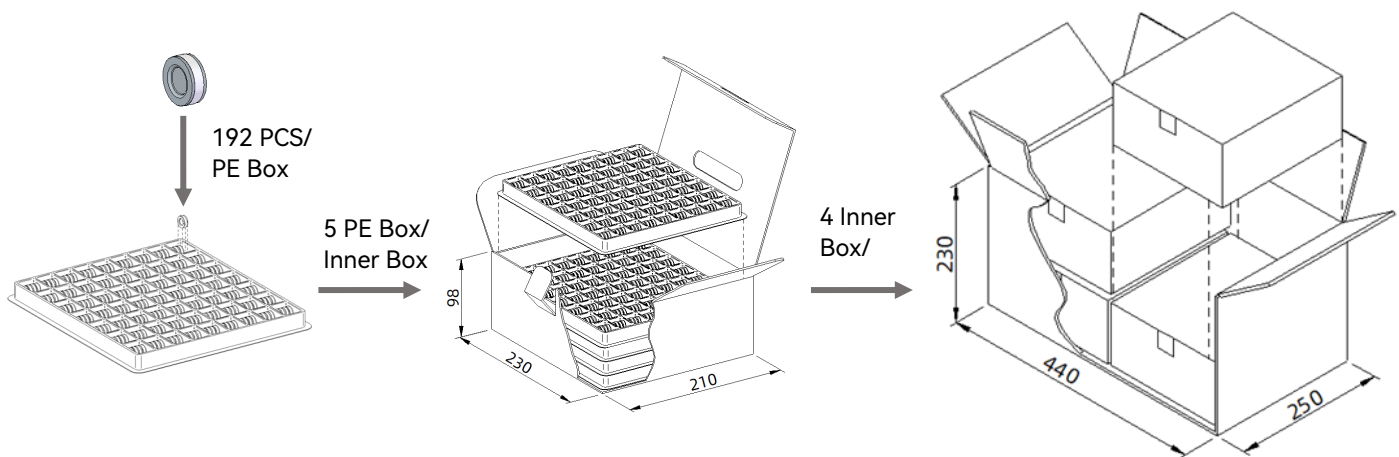

The above picture packaging is only suitable for type A products. For the other appearance and packaging mode and quantity, please refer to the specification.

## Glossary

| Item           | Description  |
|----------------|--|
| $V_s$          | <p><b>D.C. Spark-over Voltage</b><br/>The voltage at which the GDT sparks over with slowly increasing d.c. voltage.</p> <p>— (IEC 61643-311)</p>   |
| $V$            | <p><b>Impulse Spark-over Voltage</b><br/>The highest Voltage which appears across the terminals of a GDT in the period between the application of an impulse of given wave-shape and the time when current begins to flow.</p> <p>— (ITU-T K.12)</p>                                   |
| $V_a$          | <p><b>Arc Voltage</b><br/>Voltage drop across the GDT during arc current flow.</p> <p>— (IEC 61643-311)</p>  |
| $V_{gl}$       | <p><b>Glow Voltage</b><br/>The peak value of the voltage drop across the GDT when a glow-current is flowing, It is sometimes called the glow mode voltage.</p> <p>— (ITU-T K.12)</p>   |
| 8/20 $\mu$ s   | <p><b>8/20 Current Impulse</b><br/>Current impulse with a nominal virtual front time of 8 <math>\mu</math>s and a nominal time to half-value of 20 <math>\mu</math>s.</p> <p>— (IEC 61643-11)</p>  |
| 10/350 $\mu$ s | <p><b>10/350 Current Impulse</b><br/>Current impulse with a nominal virtual front time of 10 <math>\mu</math>s and a nominal time to half-value of 350 <math>\mu</math>s.</p> <p>— (IEC 61643-11)</p>  |
| 1.2/50 $\mu$ s | <p><b>1.2/50 Voltage Impulse</b><br/>Voltage impulse with a nominal virtual front time of 1.2 <math>\mu</math>s and a nominal time to half-value of 50 <math>\mu</math>s.</p> <p>— (IEC 61643-11)</p>  |
| $I$            | <p><b>Alternating Discharge Current</b><br/>The r.m.s. value of an approximately sinusoidal alternating current passing through the gas discharge tube.</p> <p>— (ITU-T K.12)</p>  |
| $I_n$          | <p><b>Nominal Discharge Current</b><br/>Crest value of the current through the GDT having a current waveshape of 8/20 <math>\mu</math>s.</p> <p>— (IEC 61643-11)</p>   |
| $I_{max}$      | <p><b>Maximum Discharge Current</b><br/>Crest value of a current through the GDT having an 8/20 <math>\mu</math>s waveshape and magnitude according to the manufacturers specification. <math>I_{max}</math> is equal to or greater than <math>I_n</math>.</p> <p>— (IEC 61643-11)</p> |

|                 |  |
|-----------------|--|
| $I_{imp}$       | <p><b>Impulse Discharge Current</b><br/>Crest value of a discharge current through the SPD with specified charge transfer Q and specified energy W/R in the specified time.<br/>— (IEC 61643-11)</p>   |
| $U_p$           | <p><b>Voltage Protection Level</b><br/>Maximum voltage to be expected at the SPD terminals due to an impulse stress with defined voltage steepness and an impulse stress with a discharge current with given amplitude and waveshape.<br/>— (GB 18802.11、IEC 61643-11)</p> |
| $U_c$           | <p><b>maximum r.m.s. voltage</b><br/>Which may be continuously applied to the SPD's mode of protection.<br/>— (IEC 61643-11)</p>   |
| $I_f$           | <p><b>follow current</b><br/>Peak current supplied by the electrical power system and flowing through the SPD after a discharge current impulse.<br/>— (IEC 61643-11)</p>  |
| <b>class I</b>  | <p><b>class I tests</b><br/>Tests carried out with the impulse discharge current <math>I_{imp}</math>, with an 8/20 current impulse with a crest value equal to the crest value of <math>I_{imp}</math>, and with a 1.2/50 voltage impulse.<br/>— (IEC 61643-11)</p>       |
| <b>class II</b> | <p><b>class II tests</b><br/>Tests carried out with the nominal discharge current <math>I_n</math>, and the 1.2/50<math>\mu</math>s voltage impulse.<br/>— (IEC 61643-11)</p>  |



# ATTENTION

## Usage

1. Do not operate GDT in power supply networks, whose maximum operation voltage exceeds the minimum spark-overvoltage of the GDT.
2. The GDT may become hot in the event of longer periods of current stress (burn risk). In the event of overload the connectors may fail or the component may be destroyed.
3. If the contacts of GDT are defective, current load can cause sparks and loud noises.
4. When air pressure is from 55 kPa to 106 kPa. The relative altitude shall be +5000 m to -500 m.

## Replacement

The GDT is a non-repairable product. For safety sake, please use equivalent GDT for replacement.

## Storage

The packaged GDT should be placed in a dry, ventilation and non-corrosive environment.

## Installation Position

Do not install the GDT in a touchable position.



## Mechanical Stress

Do not take violent action such as knocking when assembling, to avoid product failure.

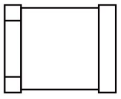
**Gas Discharge Tube (GDT) Features & Model List Overview**

| DC Spark-over Voltage (V)  | Model   |                 |                 |                 |                 |   |                 |                 |                 |
|--|---|-----------------|-----------------|-----------------|-----------------|---|-----------------|-----------------|-----------------|
|  | SZ (-SMD)   | SW (-SMD)       | SX (-SMD)       | SY (-SMD)       | SN (-SMD)       | SU (-SMD)   | SS (-SMD)       | SD (-SMD)       | SE (-SMD)       |
| 4500   | ○   | ○               | ○               | ○               | ○               | ○   | ○               | ○               | SE (-SMD)       |
| 4000   | ○   | ○               | ○               | ○               | ○               | ○   | ○               | ○               | SE (-SMD)       |
| 3600   | ○   | ○               | ○               | ○               | ○               | ○   | ○               | ○               | SE (-SMD)       |
| 3000   | ○   | ○               | ○               | ○               | ○               | ○   | ○               | ○               | SE (-SMD)       |
| 2500   | ○   | ○               | ○               | ○               | ○               | ○   | ○               | ○               | SE (-SMD)       |
| 2000   | ○   | ○               | ○               | ○               | ○               | ○   | ○               | ○               | SE (-SMD)       |
| 1500   | ○   | ○               | ○               | ○               | ○               | ○   | ○               | ○               | SE (-SMD)       |
| 1200   | ○   | ○               | ○               | ○               | ○               | ○   | ○               | ○               | SE (-SMD)       |
| 1000   | ○   | ○               | ○               | ○               | ○               | ○   | ○               | ○               | SE (-SMD)       |
| 800  | ○   | SW (-SMD)       | SX (-SMD)       | SY (-SMD)       | SN (-SMD)       | SU (-SMD)   | SS (-SMD)       | SD (-SMD)       | SE (-SMD)       |
| 600  | ○   | SW (-SMD)       | SX (-SMD)       | SY (-SMD)       | SN (-SMD)       | SU (-SMD)   | SS (-SMD)       | SD (-SMD)       | SE (-SMD)       |
| 470  | ○   | SW (-SMD)       | SX (-SMD)       | SY (-SMD)       | SN (-SMD)       | SU (-SMD)   | SS (-SMD)       | SD (-SMD)       | SE (-SMD)       |
| 420  | ○   | SW (-SMD)       | SX (-SMD)       | SY (-SMD)       | SN (-SMD)       | SU (-SMD)   | SS (-SMD)       | SD (-SMD)       | SE (-SMD)       |
| 400  | SZ (-SMD)   | SW (-SMD)       | SX (-SMD)       | SY (-SMD)       | SN (-SMD)       | ○   | ○               | ○               | ○               |
| 350  | ○   | SW (-SMD)       | SX (-SMD)       | SY (-SMD)       | SN (-SMD)       | SU (-SMD)   | SS (-SMD)       | SD (-SMD)       | SE (-SMD)       |
| 300  | SZ (-SMD)   | SW (-SMD)       | SX (-SMD)       | SY (-SMD)       | SN (-SMD)       | ○   | ○               | ○               | ○               |
| 250  | ○   | ○               | ○               | ○               | ○               | SU (-SMD)   | SS (-SMD)       | SD (-SMD)       | SE (-SMD)       |
| 230  | SZ (-SMD)   | SW (-SMD)       | SX (-SMD)       | SY (-SMD)       | SN (-SMD)       | SU (-SMD)   | SS (-SMD)       | SD (-SMD)       | SE (-SMD)       |
| 200  | SZ (-SMD)   | SW (-SMD)       | SX (-SMD)       | SY (-SMD)       | SN (-SMD)       | ○   | ○               | ○               | ○               |
| 150  | SZ (-SMD)   | SW (-SMD)       | SX (-SMD)       | SY (-SMD)       | SN (-SMD)       | SU (-SMD)   | SS (-SMD)       | SD (-SMD)       | SE (-SMD)       |
| 90   | SZ (-SMD)   | SW (-SMD)       | SX (-SMD)       | SY (-SMD)       | SN (-SMD)       | SU (-SMD)   | SS (-SMD)       | SD (-SMD)       | SE (-SMD)       |
| 75   | ○   | SW (-SMD)       | SX (-SMD)       | SY (-SMD)       | SN (-SMD)       | ○   | SS (-SMD)       | SD (-SMD)       | SE (-SMD)       |
| 70   | ○   | ○               | ○               | ○               | SN (-SMD)       | ○   | SS (-SMD)       | SD (-SMD)       | SE (-SMD)       |
| <b>Size ( mm )</b>   | 3.2 × 1.6 × 1.6   | 3.2 × 2.5 × 2.5 | 4.5 × 3.2 × 2.7 | 4.0 × 3.5 × 3.5 | 4.2 × 5.0 × 5.0 | 5.0 × 5.4 × 5.4   | 4.2 × 6.2 × 6.2 | 5.0 × 5.4 × 5.4 | 6.0 × 8.3 × 8.3 |
| <b>I<sub>n</sub> ( 8/20 μs ) (kA)</b><br>Impulse Discharge Current | 0.5   | 1               | 1 / 2           | 3               | 5               | 5 / 10  | 5               | 5               | 5 / 10 / 20     |
| <b>Product Structure</b>   |  |                 |                 |                 |                 |  |                 |                 |                 |
|  | SMD   |                 |                 |                 |                 |   |                 |                 |                 |

**Gas Discharge Tube (GDT) Features & Model List Overview**

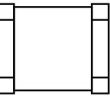
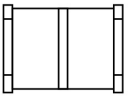
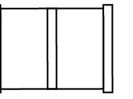
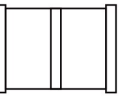
| DC Spark-over Voltage (V)  | Model   |   |   |  |   |   |                  |
|--|---|---|---|--|---|---|------------------|
|  | SK (-SMD)   | SC (-SMD)   | SF (-SMD)   | TS (-SMD)  | TZ (-SMD)   | TY (-SMD)   | TR (-SMD)        |
| 4500   | ○   | ○   | SF (-SMD)   | ○  | ○   | ○   | ○                |
| 4000   | ○   | ○   | SF (-SMD)   | ○  | ○   | ○   | ○                |
| 3600   | ○   | ○   | SF (-SMD)   | ○  | ○   | ○   | ○                |
| 3000   | ○   | ○   | SF (-SMD)   | ○  | ○   | ○   | ○                |
| 2500   | ○   | ○   | SF (-SMD)   | ○  | ○   | ○   | ○                |
| 2000   | ○   | ○   | SF (-SMD)   | ○  | ○   | ○   | ○                |
| 1500   | ○   | ○   | SF (-SMD)   | ○  | ○   | ○   | ○                |
| 1200   | ○   | ○   | SF (-SMD)   | ○  | ○   | ○   | ○                |
| 1000   | SK (-SMD)   | ○   | SF (-SMD)   | ○  | ○   | ○   | ○                |
| 800  | SK (-SMD)   | SC (-SMD)   | SF (-SMD)   | ○  | ○   | ○   | ○                |
| 600  | SK (-SMD)   | SC (-SMD)   | SF (-SMD)   | TS (-SMD)  | TZ (-SMD)   | TY (-SMD)   | TR (-SMD)        |
| 470  | ○   | SC (-SMD)   | SF (-SMD)   | TS (-SMD)  | TZ (-SMD)   | ○   | TR (-SMD)        |
| 420  | SK (-SMD)   | SC (-SMD)   | SF (-SMD)   | TS (-SMD)  | TZ (-SMD)   | TY (-SMD)   | TR (-SMD)        |
| 400  | ○   | ○   | ○   | ○  | ○   | ○   | ○                |
| 350  | SK (-SMD)   | SC (-SMD)   | SF (-SMD)   | ○  | TZ (-SMD)   | TY (-SMD)   | TR (-SMD)        |
| 300  | ○   | ○   | ○   | TS (-SMD)  | ○   | ○   | ○                |
| 250  | ○   | SC (-SMD)   | SF (-SMD)   | ○  | ○   | TY (-SMD)   | ○                |
| 230  | ○   | SC (-SMD)   | SF (-SMD)   | TS (-SMD)  | TZ (-SMD)   | TY (-SMD)   | TR (-SMD)        |
| 200  | ○   | ○   | ○   | TS (-SMD)  | TZ (-SMD)   | ○   | ○                |
| 150  | ○   | SC (-SMD)   | SF (-SMD)   | TS (-SMD)  | TZ (-SMD)   | ○   | TR (-SMD)        |
| 90   | SK (-SMD)   | SC (-SMD)   | SF (-SMD)   | TS (-SMD)  | TZ (-SMD)   | ○   | TR (-SMD)        |
| 75   | ○   | SC (-SMD)   | SF (-SMD)   | ○  | TZ (-SMD)   | ○   | ○                |
| 70   | ○   | SC (-SMD)   | SF (-SMD)   | ○  | ○   | ○   | ○                |
| <b>Size ( mm )</b>   | Φ8.0 × 2.2  | 6.0 × 8.3 × 8.3   | 6.0 × 6.0 × 6.0   | 6.8 × 3.5 × 3.5  | 7.6 × 5.0 × 5.0   | 7.8 × 5.0 × 5.0   | 10.0 × 8.3 × 8.3 |
| <b>I<sub>n</sub> ( 8/20 μs ) (kA)</b><br>Impulse Discharge Current | 10 / 20   | 20  | 3 / 5 / 10  | 3  | 5 / 10  | 5   | 10 / 20          |
| <b>Product Structure</b>   |  |  |  | <br>SMD |  |  |                  |

### Gas Discharge Tube (GDT) Features & Model List Overview

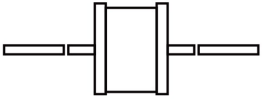
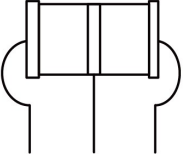
| DC Spark-over Voltage (V)                         | Model   |            |             |            |   |             |
|---|---|------------|-------------|------------|---|-------------|
|   | SD (-L)   | SF (-L)    | SE (-L)     | TZ (-L)    | TB (-L)   | TR (-L)     |
| 4500  |   | ○          | SE (-L)     | ○          | ○   | ○           |
| 4000  | ○   | SF (-L)    | SE (-L)     | ○          | ○   | ○           |
| 3600  | ○   | SF (-L)    | SE (-L)     | ○          | ○   | ○           |
| 3000  | ○   | SF (-L)    | SE (-L)     | ○          | ○   | ○           |
| 2500  | ○   | SF (-L)    | SE (-L)     | ○          | ○   | ○           |
| 2000  | ○   | SF (-L)    | SE (-L)     | ○          | ○   | ○           |
| 1500  | ○   | SF (-L)    | SE (-L)     | ○          | ○   | ○           |
| 1200  | ○   | ○          | SE (-L)     | ○          | ○   | ○           |
| 1000  | ○   | SF (-L)    | SE (-L)     | ○          | ○   | ○           |
| 800   | SD (-L)   | SF (-L)    | SE (-L)     | ○          | ○   | ○           |
| 600   | SD (-L)   | SF (-L)    | SE (-L)     | TZ (-L)    | TB (-L)   | TR (-L)     |
| 470   | SD (-L)   | SF (-L)    | SE (-L)     | TZ (-L)    | TB (-L)   | TR (-L)     |
| 420   | SD (-L)   | SF (-L)    | SE (-L)     | TZ (-L)    | TB (-L)   | TR (-L)     |
| 400   | ○   | ○          | ○           | ○          | ○   | ○           |
| 350   | SD (-L)   | SF (-L)    | SE (-L)     | TZ (-L)    | TB (-L)   | TR (-L)     |
| 300   | ○   | ○          | ○           | ○          | ○   | ○           |
| 250   | SD (-L)   | SF (-L)    | SE (-L)     | ○          | ○   | ○           |
| 230   | SD (-L)   | SF (-L)    | SE (-L)     | TZ (-L)    | TB (-L)   | TR (-L)     |
| 200   | ○   | ○          | ○           | TZ (-L)    | ○   | ○           |
| 150   | SD (-L)   | SF (-L)    | SE (-L)     | TZ (-L)    | TB (-L)   | TR (-L)     |
| 90  | SD (-L)   | SF (-L)    | SE (-L)     | TZ (-L)    | TB (-L)   | TR (-L)     |
| 75  | SD (-L)   | SF (-L)    | SE (-L)     | TZ (-L)    | ○   | ○           |
| 70  | SD (-L)   | SF (-L)    | SE (-L)     | ○          | ○   | ○           |
| Size (mm)   | Φ5.0 × 5.0  | Φ5.5 × 6.0 | Φ8.0 × 6.0  | Φ5.0 × 7.6 | Φ6.0 × 8.2  | Φ8.0 × 10.0 |
| $I_n$ (8/20 μs) (kA)<br>Impulse Discharge Current | 5   | 3 / 5 / 10 | 5 / 10 / 20 | 5 / 10     | 10  | 10 / 20     |
| Product Structure                                 |  |            |             | DIP        |  |             |

### Gas Discharge Tube (GDT) Features & Model List Overview

| DC Spark-over Voltage (V)  | Model  |             |             |              |             |             |               |              |             |              |             |              |              |                |     |
|--|--|-------------|-------------|--------------|-------------|-------------|---------------|--------------|-------------|--------------|-------------|--------------|--------------|----------------|-----|
|  | 1  | 2           | 3           | 4            | 5           | 6           | 7             | 8            | 9           | 10           | 11          | 12           | 13           | 14             | 15  |
| 4500   | ○  | ○           | ○           | ○            | ○           | ○           | ○             | ○            | ○           | ○            | ○           | ○            | ○            | ○              | ○   |
| 4000   | ○  | ○           | ○           | ○            | ○           | ○           | ○             | ○            | ○           | ○            | ○           | ○            | ○            | ○              | ○   |
| 3600   | ○  | ○           | ○           | ○            | ○           | ○           | ○             | ○            | ○           | ○            | ○           | ○            | ○            | ○              | ○   |
| 3000   | ○  | ○           | ○           | ○            | ○           | ○           | ○             | ○            | ○           | SPR          | ○           | ○            | ○            | ○              | ○   |
| 2500   | ○  | ○           | ○           | ○            | ○           | ○           | ○             | ○            | ○           | ○            | ○           | ○            | ○            | ○              | ○   |
| 2000   | ○  | SPB         | ○           | ○            | ○           | ○           | ○             | ○            | ○           | SPR          | ○           | ○            | ○            | ○              | ○   |
| 1500   | SPA  | SPB         | ○           | SPJ          | SPI         | ○           | ○             | ○            | ○           | ○            | ○           | ○            | ○            | ○              | ○   |
| 1400   | ○  | ○           | ○           | ○            | ○           | ○           | ○             | ○            | ○           | ○            | ○           | ○            | ○            | ○              | TPA |
| 1000   | ○  | SPB         | SPC         | SPJ          | ○           | ○           | ○             | ○            | ○           | ○            | ○           | ○            | ○            | ○              | ○   |
| 800  | SPA  | SPB         | SPC         | SPJ          | SPI         | SPH         | SPK           | SPP          | SPR         | SPS          | SPV         | SPZ          | SPO          | TPA            | ○   |
| 600  | SPA  | SPB         | SPC         | SPJ          | SPI         | SPH         | SPK           | SPP          | SPR         | SPS          | SPV         | SPZ          | SPO          | ○              | ○   |
| 470  | ○  | ○           | ○           | ○            | ○           | ○           | ○             | ○            | ○           | ○            | ○           | ○            | ○            | ○              | ○   |
| 420  | ○  | ○           | ○           | ○            | ○           | ○           | ○             | ○            | ○           | ○            | ○           | ○            | ○            | ○              | ○   |
| 400  | ○  | ○           | ○           | ○            | ○           | ○           | ○             | ○            | ○           | ○            | ○           | ○            | ○            | ○              | ○   |
| 350  | SPA  | SPB         | SPC         | SPJ          | SPI         | SPH         | ○             | ○            | ○           | ○            | SPV         | SPZ          | ○            | ○              | ○   |
| 300  | ○  | ○           | ○           | ○            | ○           | ○           | ○             | ○            | ○           | ○            | ○           | ○            | ○            | ○              | ○   |
| 250  | ○  | ○           | ○           | ○            | ○           | ○           | ○             | ○            | ○           | ○            | ○           | ○            | ○            | ○              | ○   |
| 230  | ○  | ○           | ○           | ○            | ○           | ○           | ○             | ○            | ○           | ○            | ○           | ○            | ○            | ○              | ○   |
| 200  | ○  | ○           | ○           | ○            | ○           | ○           | ○             | ○            | ○           | ○            | ○           | ○            | ○            | ○              | ○   |
| 150  | ○  | SPB         | ○           | ○            | ○           | ○           | ○             | ○            | ○           | ○            | ○           | ○            | ○            | ○              | ○   |
| 90   | ○  | SPB         | ○           | ○            | ○           | ○           | ○             | SPK          | ○           | ○            | ○           | ○            | ○            | ○              | ○   |
| 75   | ○  | ○           | ○           | ○            | ○           | ○           | ○             | ○            | ○           | ○            | ○           | ○            | ○            | ○              | ○   |
| 70   | ○  | ○           | ○           | ○            | ○           | ○           | ○             | ○            | ○           | ○            | ○           | ○            | ○            | ○              | ○   |
| <b>Size ( mm )</b>   | Φ11.8 × 16.0   | Φ11.8 × 6.2 | Φ11.8 × 4.2 | Φ16.0 × 4.5  | Φ16.0 × 8.0 | Φ18.0 × 6.7 | Φ15.0 × 3.0   | Φ30.0 × 12.0 | Φ20.0 × 6.0 | Φ24.0 × 10.0 | Φ20.0 × 4.0 | Φ11.8 × 12.0 | Φ30.0 × 30.0 | 16 × 8.4 × 9.3 |     |
| <b>I<sub>n</sub> ( 8/20 μs ) (kA)</b><br>Impulse Discharge Current | 20 / 30 / 40   | 20          | 20 / 30     | 20 / 30 / 40 | 30          | 40          | 25 / 50 / 100 | 20 / 40      | 80          | 40           | 20 / 40     | 100          | 20           |                |     |
| <b>Product Structure</b>   |  |             |             |              |             |             |               |              |             |              |             |              |              |                |     |

High Current  
(May increase each kind of connect mode according to the customer different demand.)